



## FCD360Q 脉冲电磁阀 Coil components

### 性能参数 FUNCTION PARAMETERS

额定电压 Rated Voltage	DC6V 12V 24V 36V
适用水压 Pressure Range	0.02~0.8MPa
使用寿命 Operate Life	≥ 100000 次 OPS
进水口 Inlet	G1/2外螺纹 external thread
出水口 Outlet	G1/2外螺纹 external thread

### 尺寸图 DIMENSIONS

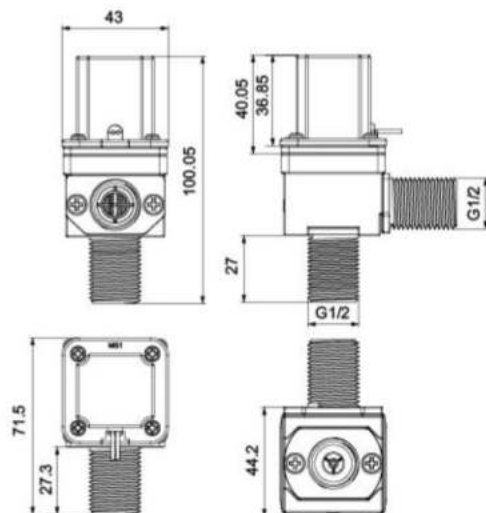

\* 可根据客户需求专业定制。  
Specification and design can be customized

### 流量特性 FLOW CHARACTERISTIC

水压 Hydraulic Pressure	0.3MPa
流量 Flow Rate	> 33L/min